



Owner's Manual

Model #s: UTX110, UTX150, UTX200
110, 150, & 200 Gallon Trailer Sprayer

Dealer: _____
Contact: _____
Phone: _____
Model #: _____
Serial #: _____

Manufactured by PBZ LLC
A Paul B Zimmerman Inc. Company
www.CropCareEquipment.com

Form: UTXOM
Rev. A Date: 1/2025

Table Of Contents

Identification of Machine	3	CropCare® Limited Warranty	30
Introduction	3	Warranty Coverage.....	30
Safety	4-11	Warranty is Void if	30
Safety Alert Symbol.....	4	Getting Warranty Service	30
Signal Words	4	Ordering Parts.....	30
Hazards	5	Parts List & Breakdowns	30
Preparation for Use	5-7		
General Guidelines	5		
Chemical Warnings	5-6		
Pump Precautions	6		
Spraying Preparation.....	6-7		
During Use	7-8		
Clearing Blockages and Cleaning.....	8		
Transporting the Sprayer.....	9		
Maintenance and Adjustment.....	9		
After Use / Storage.....	9		
Safety Signs.....	10-11		
Operation	12-23		
Operating Instructions.....	12-21		
Controls.....	12-13		
Pre-start Instructions	14-18		
Preparing the Sprayer	14		
Priming the Pump.....	14		
Using the Quick Fill	15		
Calibrating the Sprayer.....	15-17		
Manual Rate Control.....	15		
Automatic Rate Control.....	15		
Determining the Speed.....	16		
Calc. the GPM & Using Calibration Chart	17		
Adjusting the Sprayer Pressure	17		
Calibration Chart	17		
Verify the Flow Rate.....	17		
Preparing to Spray.....	18		
During Operation	19		
Following Operation	19		
Instructions for Clearing Blockages & Cleaning.....	20		
Troubleshooting.....	21-22		
Plumbing Diagrams	23-24		
Maintenance and Adjustments.....	25-27		
Maintenance Schedules	25		
Maintenance Procedures	25-26		
Every Use	25		
Every Season.....	25-26		
Preparing the Sprayer for Winterizing	26		
Winterizing the Sprayer	26		
Maintenance Materials	27		
Adjustments	27		
Storage	27		
Transportation.....	28		
Accessories and Attachments.....	28-29		
Gas Engine Electric Start Option	28		
Electric Hose Reel Option	29		

Identification of Machine

- Model #s: UXT110, UTX150, UTX200
- The serial number plate is located on side of the tank saddle.

Introduction

Please read and understand this manual and its instructions and warnings completely before operating the sprayer.

- Read and understand the chemical manufacturer's labels, warnings, and instructions.
- Know and fulfill all state pesticide applicator license requirements.
- Familiarize yourself and other operators with the sprayer's components and how all parts are operated.
- Contact your authorized CropCare[®] dealer for help interpreting the owners manual.
- Read and follow ALL of the chemical manufacturer's labels, warnings, and instructions about chemical usage! A material safety data sheet (MSDS) should be provided by the chemical manufacturer. CropCare[®] is not liable for misuse or mishandling of chemicals before spraying, during spraying, and after spraying.

Safety Alert Symbol

-The safety alert symbol for safety signs & decals that contain one of the three signal words (DANGER, WARNING, & CAUTION) will appear as shown in figure 1.



Figure 1: Safety Alert Symbol

Signal Words

-There are three signal words; DANGER, WARNING, and CAUTION. The signal words bring attention to the existence and relative seriousness of a hazard.

- **DANGER:** The signal word DANGER indicates an imminently hazardous situation which, if not avoided, will result in death or serious injury
- **WARNING:** The signal word WARNING indicates a potentially hazardous situation which, if not avoided, could result in death or serious injury.
- **CAUTION:** The signal word CAUTION indicates a potentially hazardous situation which, if not avoided, may result in minor or moderate injury.

-Additional Signal Words.

- **NOTE:** The signal word NOTE provides information on operator safety and operator tips.
- **IMPORTANT:** The signal word IMPORTANT indicates a recommended action or a restriction that will ensure correct equipment operation and performance.

Hazards



Preparation for Use



1.) General Guidelines

Every year many unnecessary accidents occur due to improper equipment handling and a disregard for safety precautions. You, the operator, can avoid accidents by observing the precautions in this section.

- The best defense against accidents is a careful and responsible operator.
- The operator should be a responsible adult. Do not allow persons to operate this sprayer until they have displayed a thorough understanding of sprayer safety precautions and operational use!
- Never attempt to operate this sprayer when under the influence of alcohol or drugs.
- Practicing safe PTO operation is immensely important! Failure to keep body parts or clothing clear of the sprayer's PTO drive shaft could result in serious injury or death. CropCare® assumes no liability for any possible injury.
- Be aware of the PTO warning decal on the PTO drive shaft (Figure 1).
- Never step over, or work near the PTO drive shaft during operation.
- Always replace any missing or damaged PTO shields!
- ALL replacement parts need to be an OEM part or an aftermarket equivalent
- If there is any portion of this manual that you do not fully understand, please contact the original retailer.
- Review specifications and ensure that this product is only used with a compatible tow vehicle.
- Never exceed the maximum lift or towing capacity specified by the tow vehicle manufacturer.



Figure 1: PTO Warning Decal

2.) Chemical Warnings

- All operators must also fulfill state pesticide applicator license requirements!
- Be aware of the chemical warning decal on the sprayer tank (Figure 2).
- Read and follow chemical manufacturer's labels, warnings, and instructions! A material safety data sheet (MSDS) should be provided by the chemical manufacturer.

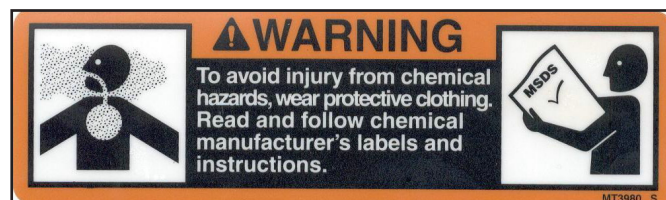

Figure 2: Chemical Warning Decal (DEMT3980)

2.) Chemical Warnings...Continued

- To avoid injury from chemical hazards, wear the proper protective clothing. Each chemical manufacturer's clothing requirements are listed under the "Personal Protective Equipment (PPE)" section in the chemical instructions.
- If the sprayer is equipped with the fresh water safety rinse option, clean water from the rinse tank can be dispensed through the drum valve on the side of the tank to cleanse yourself of harmful chemical contact.
- Never put chemicals or any substances other than clean fresh water in the rinse tank. Be aware of the fresh water warning decal (Figure 3).



Figure 3: Fresh Water Only decal (DE21)

3.) Pump Precautions

- Never operate the pump at pressures over the manufacturer's recommended maximum pressure. Operating the pump at pressures over the recommended maximum pressure can cause damage to the pump, the controls, or cause personal injury. Operating the pump at pressures over the recommended maximum pressure will void the manufacturer's warranty.
- IMPORTANT: Shutting off boom sections during operation will cause a spike in pump pressure.
- Never pump flammable or explosive fluids such as gasoline, fuel oil, kerosene, etc.
- Never run the pump faster than the recommended maximum rpm.
- Never pump liquids at temperatures higher than the recommended maximum temperature (140°F / 60°C) Do not exceed this temperature.
- Before servicing your pump, disconnect the power, release all pressure, and drain all liquids.
- See the pump owner's manual for maximum RPM and pressure ratings.

4.) Spraying Preparation

- Be aware of the location of all the safety and warning decals. Always replace any decals that are illegible or are missing.
- Carefully study and understand this owner's manual.
- Be aware of the owner's manual decal (Figure 1).
- Before adding chemicals, have all operators practice operating the sprayer (clean water only) and its attachments until all operators are completely capable of safe operation.
- Do not wear loose-fitting clothing which may catch in moving parts.
- Visually inspect the sprayer for any worn parts, loose bolts, or other visible problems, and make the necessary repairs.

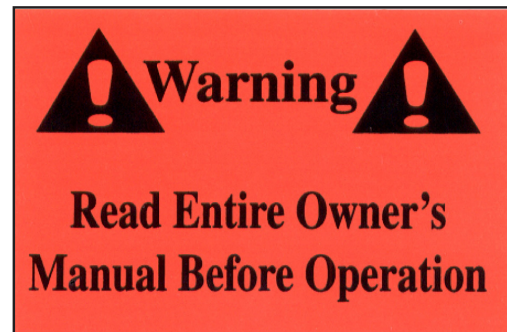

Figure 1: Owner's Manual Decal (DE39)

4.) Spraying Preparation...Continued

- **DANGER:** Never check for hydraulic hose leaks with your hands. If oil penetrates the skin and enters the bloodstream, the results could be fatal. If there is any visible damage to the hoses, replace them immediately.
- All sprayer maintenance should be performed with the sprayer unhooked from the tractor and clean of any harmful chemicals.
- To avoid injury from chemical hazards, always wear the proper personal protective equipment (PPE).
- Make sure the area is clear of any people or obstructions before using the sprayer.
- Make sure to only use the designated operators platform to climb onto sprayer (if equipped) (Figure 2).



Figure 2: Climbing on Sprayer (DE141)

During Use

- Always be aware of bystanders, particularly children! Always look before moving the sprayer or engaging the PTO. Bystanders should never be allowed near the sprayer during operation.
- No passengers are allowed on or in the tractor or sprayer at any time.
- A hydraulic folding boom, if improperly operated, can be very dangerous to the operator and/or bystanders. Do not allow anyone near the boom during operation or anytime the hydraulic system is engaged.
- Be aware of the boom's moving parts and the portions of the boom where the risk of pinching is high. It is also important to remember that the boom extends and swings in a fast progression. When extending the boom be aware of any obstructions that could damage the boom.
- Be aware of all the safety and warning decals on the boom (Figures 1-5).
- If a hydraulic boom's movement is too fast or jolting, the hydraulic flow on most tractors can be adjusted. Proper flow adjustment can further increase the safety of the sprayer.
- Keep hands and body parts clear of all moving parts, especially the tractor PTO.
- Only disconnect sprayer on a solid level surface. The tank must be empty.
- Be aware of dangerous terrain such as holes, slopes, drop-



Figure 1: Swinging boom warning decal (DE26)



Figure 2: Moving parts warning decal (DE24)

offs, banks, rocks, and hidden hazards. Operate the tow vehicle and sprayer up and down slopes, not across.

- When operating on inclines, it is especially important that your tow vehicle is equipped with Roll Over Protection System (ROPS).
- IMPORTANT: Be sure to allow enough room for sprayer boom wings to clear obstacles when making turns.
- Never leave running equipment unattended!
- Remember that accidents can even happen to seasoned operators. Always take your time and follow all safety instructions.



Figure 4: Disconnecting Sprayer (DE136)



Figure 3: Pinch point decal (DE23)



Figure 5: Pinch point decal (DE22)

Clearing Blockages and Cleaning

- Wear chemical resistant gloves and eye protection at all times while clearing blockages and cleaning the sprayer.
- Before clearing blockages and cleaning, make sure the sprayer and rinse tank is drained entirely.
- Make sure the sprayer is parked on level ground before clearing blockages and cleaning the sprayer.
- Do not stand on the sprayer while clearing blockages and cleaning the sprayer.
- CAUTION: Be sure to THOROUGHLY wash any skin that has been exposed to chemicals after clearing blockages and cleaning the sprayer.

Transporting the Sprayer

- When transporting the sprayer on public roads, always follow state and local regulations regarding safety and transportation requirements. Use the necessary lights and slow moving vehicle (SMV) emblems.
- Never exceed the tow vehicle's load and/or tow ratings.
- When transporting the sprayer, the sprayer's boom must be in the fully closed position and secured. If the sprayer is equipped with a hydraulic boom, the boom is secured by closing the ball valve located on the hydraulic folding cylinder (Figure 1).
- Check lighting before traveling.
- Make sure SMV sign is not blocked or bent.



Figure 1: Hydraulic valve warning decal (DE25)

Maintenance and Adjustment

- Wear chemical resistant gloves and eye protection at all times while performing adjustments and maintenance.
- Make sure the sprayer is parked on level ground before performing adjustments and maintenance.
- Make sure sprayer is clear of all chemical residue in the location where the adjustments are being made.
- CAUTION: Be sure to THOROUGHLY wash any skin that has been exposed to chemicals after performing adjustments and maintenance.

After Use / Storage

- Following operation, stop the tow vehicle, set the brakes, disengage PTO shaft, shut off the engine, and remove the ignition key.
- Completely rinse the entire sprayer and all of its components of all chemical residue after every use.
- Dispose of rinsate in accordance with chemical application guidelines.
- Park the sprayer on a hard level surface, away from all human and livestock activity.
- Do not permit children to play on or around sprayer.

Safety Signs

- Signs and decals used to indicate safe practices while preparing, transporting, and operating the sprayer.
- Make sure that they are not obstructed by dirt or chemical residue. Clean as necessary.
- Replacements can be ordered from a CropCare® Dealer.



Figure 1: PTO warning decal
-Located on the PTO driveline guard.

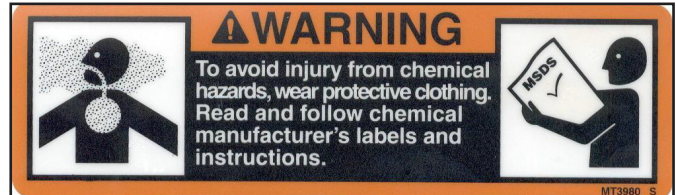

Figure 3: Chemical Warning Decal (DEMT3980)
-Located on the main tank of the sprayer.



Figure 4: Fresh Water Only decal (DE21)
-Located on rinse and safety tanks.

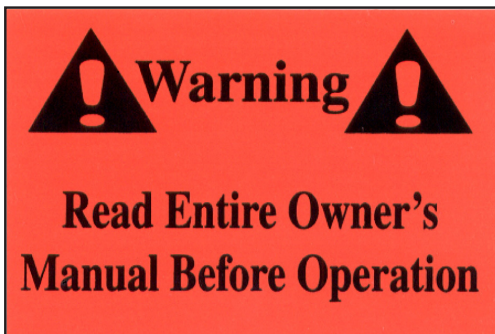

Figure 2: Owner's Manual Decal (DE39)
-Located on the main tank of the sprayer



Figure 5: Read Owner's Manual Warning (DE115)
-Located at components that require operator adjustment
-See Owner's Manual for information on components requiring operator adjustment.

Safety Signs



Figure 6: Climbing on Sprayer (DE141)
-Located on front sprayer handrail.



Figure 7: Swinging boom warning decal (DE26)
-Located on sprayer boom wings.
-Stand clear of wings when folding or unfolding.



Figure 8: Moving parts warning decal (DE24)
-Located on moving parts, mostly on the boom.
-Stand clear of moving parts on the sprayer.



Figure 9: Hydraulic valve warning decal (DE25)
-Located on hydraulic cylinders



Figure 10: Disconnecting Sprayer (DE136)
-Located near the hitch on the sprayer.

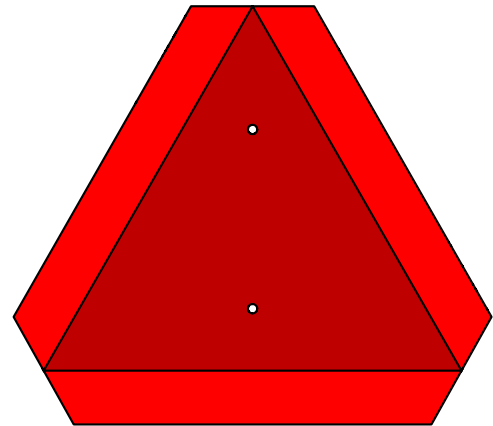

Figure 11: Slow Moving Vehicle Sign (SMV)
-Located on the rear of the sprayer.
-Indicates that this is a vehicle or implement that is traveling slower than the rate of traffic.



Figure 12: Pinch point decal (DE23)
-Located at points where moving parts come close together, mostly on the boom.
-Keep clear of pinch points.



Figure 13: Pinch point decal (DE22)
-Located at points where moving parts come close together, mostly on the boom.
-Keep clear of pinch points.

Controls

Electric Controls

- If your sprayer is equipped with electric controls, there is a control console that is used to control the spray boom sections, and to adjust the spray pressure.
- Refer to the control console's owner's manual for useful information regarding installation procedures, wiring diagrams, and operating instructions.
- There are two manual adjustments that are used with electric controls (Figure 1):
 1. Agitation is controlled by turning the knob on the valve. (Clockwise to close, and counter clockwise to open.)
 2. Maximum pressure is set by turning the adjusting screw on Max Pressure Relief Valve (if equipped) (clockwise to increase pressure, counter clockwise to decrease).

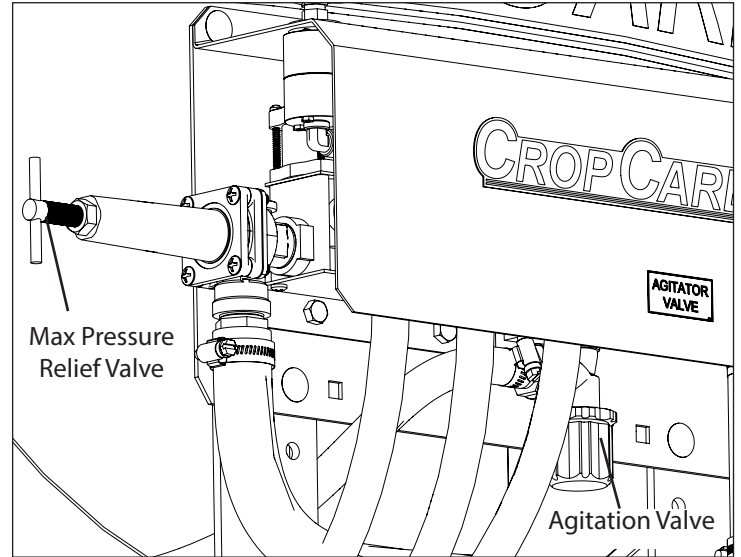

Figure 1: Adjustments with Electric Controls

Non-Electric / Manual Controls

- If your sprayer is equipped with Non-electric/manual controls, then the sprayer's boom sections, by-pass, and agitation are operated manually with valves on the sprayer. There are three optional styles for manual control. These control options consist of three adjustments.
 1. Pressure Regulating adjustments used to adjust spray pressure.
 2. Pressure Release used to set the flow from the pump to bypass entirely to tank or to the pressure setting for spraying.
 3. Valves for turning flow to boom sections on or off.

Manual Control Option 1 (Figure 2)

- Spray pressure is set by turning the adjusting screw on the Pressure Regulation Valve (clockwise to increase pressure, counter clockwise to decrease).
- Agitation is controlled by turning the knob on the valve. (Clockwise to close, and counter clockwise to open.)
- The Master Valve controls flow to all of the boom section valves.
- Boom sections valves for individual sections (closed when lever is centered, as shown).

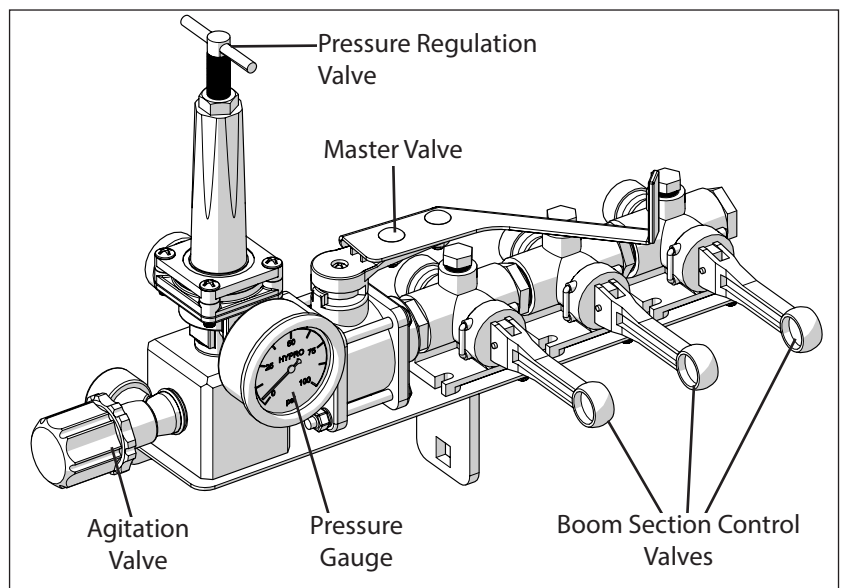

Figure 2: Manual Control Option 1

Operation

Non-Electric / Manual Controls (continued)

Manual Control Option 2 (Figure 3)

- Pressure is adjusted by clamping the Pressure Adjustment & Release Lever down.
- With the Pressure Adjustment & Release Lever hooked in the number one position, the pressure is at 100 psi, number two is 250 psi, number three is 450 psi, and number four is 550 psi.
- These pressures can be fine tuned with adjustments of the Pressure Adjustment Knob (NOTE: This can be adjusted when the Release Lever is in the up position).
- Pressure is released (full bypass) when the Release Lever is in the up position.

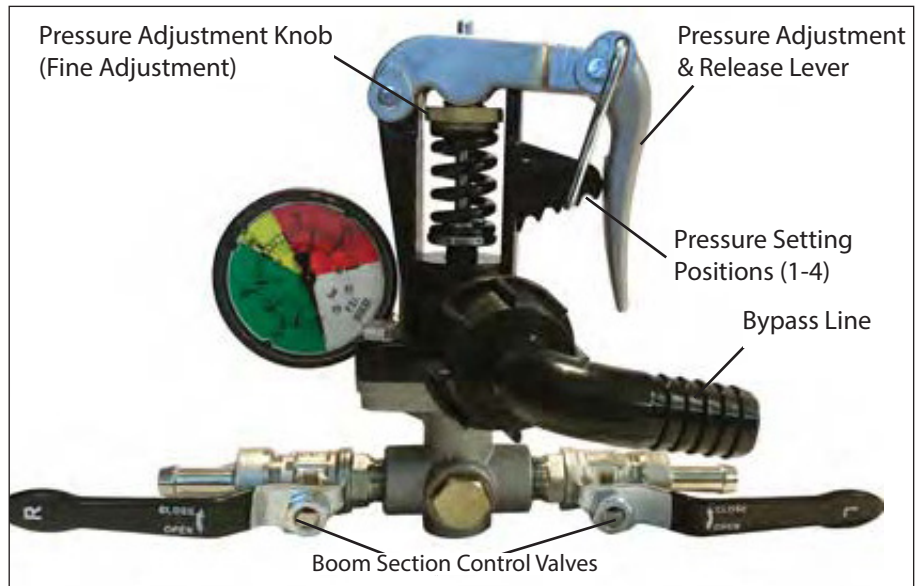

Figure 3: Manual Control Option 2

Manual Control Option 3 (Figure 4)

- Pressure is adjusted by turning the Pressure Adjustment Knob
- Pressure is released (full bypass) when the Pressure Release Knob is set with "C" in the top position.
- When spraying, turn the Pressure Release Knob so that "A" is set in the top position.

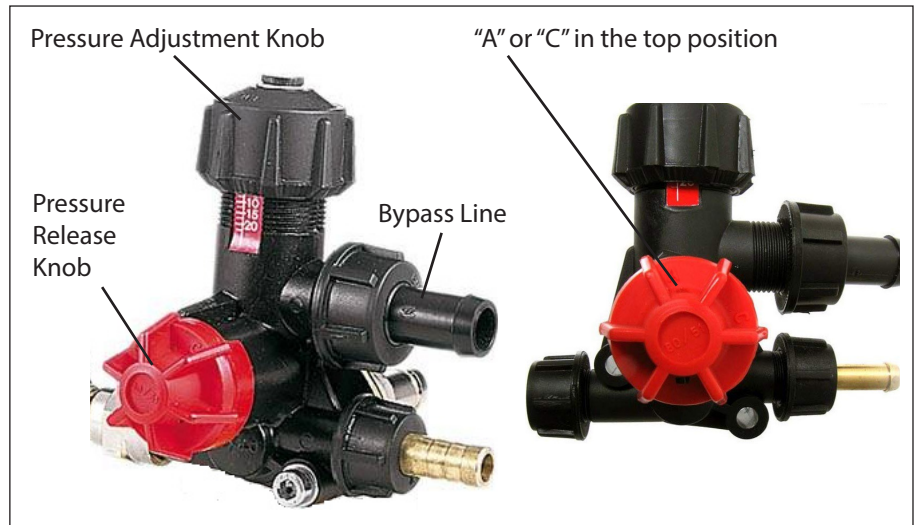

Figure 4: Manual Control Option 3

Operating Instructions

- Be sure to read and understand all operating instructions. Failure to do so could result in injury or voiding of warranty.
- Make sure to be familiar with all of the sprayer's controls before operating.

Pre-start Instructions

Preparing the Sprayer

Before operating the sprayer, it is important that you read this entire manual and know all safety precautions. Always take your time and be alert when operating your sprayer. This will allow you to safely spray without accident or interruption.

1. To avoid injury from chemical hazards, wear the proper protective clothing. Each chemical manufacturer's clothing requirements are listed under the "Personal Protective Equipment (PPE) section in the chemical's instructions.
2. Hook the sprayer up to your tractor with a high stress hitch pin. Contact your local CropCare® dealer to order an appropriate hitch pin.
3. If your sprayer is equipped with a hydraulic boom, connect the four hydraulic hoses to the tractor's hydraulic ports. The hydraulic hoses come in pairs for the left and right booms. The pairs must be connected together for proper operation.
4. Prepare the sprayer pump:
 - Roller pump: Connect the pump to the tractor's PTO.
 - Gasoline engine driven pump: See engine owner's manual for starting procedure. (NOTE: Check the engine oil, fuel, and air filter element before cold starting the engine.)
 - Hydraulic drive pump: Connect the two hydraulic hoses to the tractor's hydraulic ports. Use motor spool if available. Refer to the pump's owners manual for detailed instructions.
5. Prepare the sprayer controls for operation. If your sprayer is equipped with electric controls, mount the control box on the tractor and follow all of the manufacturer's installation instructions to ensure proper performance. See the sprayer control manual for instructions.
6. Fill the sprayer's tank with clean fresh water in order to test the sprayer. Testing the sprayer before operation will give you a chance to familiarize yourself with all of the components and to test for any leaks or problems.
7. Engage the sprayer's pump, prime the pump, see "Priming the Pump", and set the pressure using the sprayer's controls. If applicable, practice operating the sprayer's boom using the tractor's hydraulic controls. Inspect the sprayer for any leaks or problems. If you have any questions or concerns please contact your local CropCare® dealer.
8. Calibrate the sprayer using the following calibration instructions and calibration chart (see "Calibrating the Sprayer" section). This will determine what pressure to spray at and what nozzles to use in order to achieve the desired application rate.

Priming the Pump

1. To prime the pump, the liquid level in the supply tank must be at a higher elevation than the pump so that the liquid flows into the pump.
2. Open the main suction line valve located below the tank so the pump is flooded with liquid, then fully open the agitation valve (electric controls or manual control option 1) or open the bypass line using the pressure release settings (manual control options 2 or 3).
3. Engage the pump (engage PTO on tow vehicle, or start the gas engine on the sprayer) and let it operate at approximately 75% of its maximum recommended RPM.
4. If the pump does not prime, there may be air trapped in the pump head.
 - If the pump is equipped with a bleeder valve, open the bleeder valve until a steady stream of liquid flows from the bleeder hose. The bleeder valve is located on the top rear side of the pump. When bleeding the air from the pump, be sure to catch all liquid in a container and redeposit it back into the sprayer tank when finished priming.
 - If using a roller pump, disconnect from PTO and lower the pump to flood pump housing with fluid.

Operation

Using the Quick Fill (With a Transfer Pump)

1. Remove the dust cap on the quick coupler and connect the transfer hose to the coupler (Figure 1).
2. Open the valve on the nurse tank/transfer hose.
3. Open the suction valve (Figure 2) underneath the sprayer tank.
4. Open the quick fill Valve at the quick coupler (Figure 1).
5. When the spray tank approaches the desired level slowly close the quick fill valve and turn off the transfer pump.
6. Close the valve on the nurse tank/transfer hose.
7. Disconnect the transfer hose from the quick coupler and replace the dust cap.

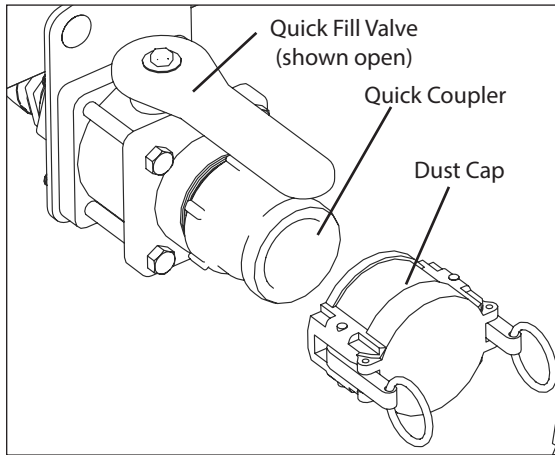

Figure 1: Quick Fill Valve

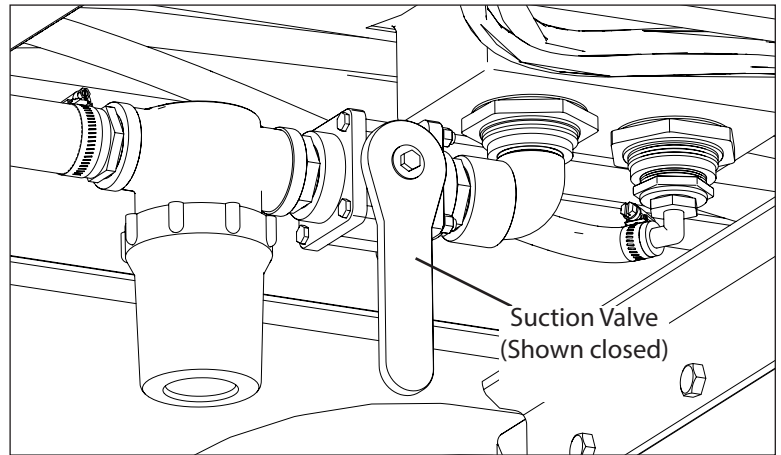

Figure 2: Suction Valve, Tank

Using the Quick Fill (With the Sprayer Pump)

NOTE: If the sprayer pump is not self-priming, then the liquid in the nurse tank needs to be positioned higher in elevation than the sprayer pump.

1. Remove the dust cap on the quick coupler and connect the transfer hose to the coupler (Figure 1).
2. Open the valve on the nurse tank/transfer hose.
3. Close the suction valve (Figure 2) underneath the sprayer tank.
4. Open the quick fill Valve at the quick coupler (Figure 1).
5. Start the sprayer pump, and fully open the agitation valve, or set controls to full bypass mode (see “Controls” section for details). If the pump does not prime, see “Priming the Pump” section.
6. When the spray tank approaches the desired level slowly close the quick fill valve and open the suction valve (Figure 2), so that the pump will circulate fluid from the sprayer tank.
7. Close the valve on the nurse tank/transfer hose.
8. Disconnect the transfer hose from the quick coupler and replace the dust cap.

Calibrating the sprayer

IMPORTANT: All calibration must be done with fresh water only!

Before spraying, the sprayer must be calibrated to ensure proper spray coverage and the desired application rate using the following steps. Before calibrating the sprayer it is important to familiarize yourself with the operating instructions (see “Operating Instructions”).

Manual Application Rate Control

1. Determine the speed of the tractor (see page 16 for details).
2. Determine spray pressure setting using the calibration chart based on the nozzle size / spacing (see page 17 for details).
3. Use the calibration chart to find the correct pressure setting, and set the pressure accordingly (see page 17 for details).

Operation

Automatic Application Rate Control

1. Determine the speed of the tractor (see page 16 for details).
2. Determine nozzle size and spacing (see page 17 for details).
3. Set the desired application rate. (See the rate controller manual for programming and operation instructions.)

1.) Determining the Speed

It is important to determine what speed the tractor will be traveling at while spraying. While some tractors have speedometers, it is still recommended that speed is calculated for all tractors for accuracy purposes. To determine the speed follow these steps:

1. Measure a 200 foot or 300 foot distance on a field or a surface similar to where you will be spraying.
2. Drive the tractor and sprayer (tank half-full is optimal) across the measured distance at a constant rate of speed. There should be no changes in speed while you are measuring the time. This should be a comfortable speed for spraying.

NOTE: When calculating tractor speed be sure to select a gear that allows the tractor to operate at full (540 RPM) PTO speed. This will allow the pump to operate at full volume. Selecting a higher gear and a lower engine speed will reduce pump performance and cause greater variations in travel speed.

3. Measure the amount of time (in seconds) it takes to travel the measured distance.
4. When measuring the time it takes to travel the measured distance, be sure that the tractor is traveling at the required speed before crossing the starting point of the measured distance. Also be sure that the tractor travels at a constant rate of speed and does not slow down until it has traveled the full measured distance.
5. Your speed can be found by entering your data into the equation or by consulting the table, both found in this section.

NOTE: It is helpful for future references to record the exact RPM and gear used to find your speed.

$$\text{Speed (mph)} = (\text{Distance (ft)} \times 60) \div (\text{Time (seconds)} \times 88)$$

Speed (MPH)	Time required (seconds) to travel a distance of:		Time required (seconds) to Cover 1/128th acre (Flow from one nozzle in ounces = GPA)			
	200 feet	300 feet	15" Nozzle Spacing	18" Nozzle Spacing	20" Nozzle Spacing	30" Nozzle Spacing
2.0	68	102	93	77	70	46
2.5	55	82	74	62	56	37
3.0	45	68	62	52	46	31
3.5	39	58	53	44	40	26
4.0	34	51	46	39	35	23
4.5	30	45	41	34	31	21
5.0	27	41	37	31	28	19
5.5	25	37	34	28	25	17
6.0	23	34	31	26	23	15
6.5	21	31	29	24	21	14
7.0	19	29	26	22	20	13
7.5	18	27	25	21	19	12
8.0	17	26	23	19	17	12

Operation

2.) Calculating the GPM and using Calibration Chart

The nozzles on your sprayer are color-coded and match the calibration chart (see section 3). Using the, tractor speed (determined in section 1), nozzle size/color, and desired gallons per acre (GPA), reference the calibration chart to find the pressure (psi) necessary to achieve the desired GPA.

$$\frac{\text{Desired GPA} \times \text{Nozzle Spacing (Inches)} \times \text{Speed}}{5940} = \text{Gallons/Minute/Nozzle}$$

Example: Assume you have found your tractor speed to be 5 MPH, your nozzles are size 03 (blue), and you want to spray 20 GPA. Upon looking at the chart, you will find that you should set the sprayer's pressure at about 50 psi in order to apply 20 GPA.

$$\frac{20 \text{ GPA} \times 20'' \times 5 \text{ MPH}}{5940} = .34 \text{ GPM/Nozzle}$$

3a.) Adjusting the Sprayer Pressure

You have found the correct pressure setting, but must now adjust the sprayer to that pressure setting. Before you adjust the sprayer's pressure, it is important to set the tractor's RPM at the same RPM that was used to find the tractor's speed. Refer to the "Controls" section for details on adjusting pressure.

IMPORTANT: Due to normal wear, TeeJet® recommends that you replace your sprayer nozzles after every spraying season. Nozzle replacement will ensure accurate spraying performance.

Calibration Chart

Nozzle Size 02 (Yellow)		Nozzle Size 025 (Lavender)		Nozzle Size 03 (Blue)		Nozzle Size 04 (Red)		Nozzle Size 05 (Brown)	
PSI	GPM/Nozzle	PSI	GPM/Nozzle	PSI	GPM/Nozzle	PSI	GPM/Nozzle	PSI	GPM/Nozzle
15	0.12	15	0.15	15	0.18	15	0.24	15	0.31
20	0.14	20	0.18	20	0.21	20	0.28	20	0.35
30	0.17	30	0.22	30	0.26	30	0.35	30	0.43
40	0.2	40	0.25	40	0.3	40	0.4	40	0.5
50	0.22	50	0.28	50	0.34	50	0.45	50	0.56
60	0.24	60	0.31	60	0.37	60	0.49	60	0.61
75	0.27	75	0.34	75	0.41	75	0.55	75	0.68
90	0.3	90	0.38	90	0.45	90	0.6	90	0.75

IMPORTANT: Flow rates are calculated using fresh water. Always remember to double check application rates.

3b.) Verify the Flow Rate

Use the following steps to verify that the flow rate of the sprayer matches the desired application rates (determined in section 2).

1. With the nozzle spacing (determined in section 4) and the speed (determined in section 1) use the speed chart (section 1) to find the amount of time required to cover 1/128th of an acre.
2. With a 2 quart spray calibration container, collect the flow from one nozzle while operating at the pressure setting determined in section 4c. for the amount of time required to cover 1/128th of an acre. The number of ounces collected will be equal to your application rate in gallons/acre (GPA).
3. Make pressure adjustments as necessary to reach the desired application rate.
4. Repeat this process for all nozzles on the sprayer and clean or replace all nozzles that deliver over 10% more or less flow than a new/unused nozzle.

Operation

Preparing to Spray

IMPORTANT: Proper personal protective equipment (PPE) must be worn at all times while handling, mixing, or spraying chemicals.

1. Fill the spray tank with the amount of water that is recommended in the chemical mixing instructions. Before filling the tank make sure the tractor's PTO or hydraulic drive system is disengaged. (NOTE: If filling the sprayer tank using the optional quick fill, see the "Using the Quick Fill" section)
2. After filling the tank with water, open the main suction line valve located below the tank (Figure 1).
3. Open the agitation valve (if equipped) or the set the controls to full bypass on the sprayer controls (see "Controls" section for details). Then engage the pump by engaging the tractor's PTO or hydraulic drive system. Confirm that the tank is agitating properly.

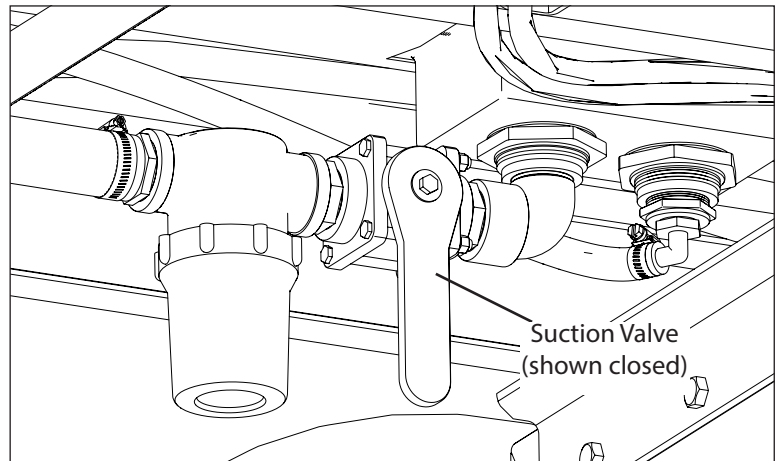

Figure 1: Suction Valve, Tank

4. If the pump does not prime, see the "Priming the Pump" section.
5. Adjust the sprayer's pressure to the pressure rating found when you calibrated your sprayer (see "Controls" section for details). NOTE: You may need to readjust the pressure when you open the boom control valves.
6. See chemical manufacturer's instructions for the proper chemical mixing sequence and the necessary agitation times.
7. Add the amount of chemicals needed for your mixture through the tank fill well.
8. If equipped with a hydraulic folding boom, ensure that the ball valves located on the boom folding cylinders are in the closed position before transporting the sprayer. Proceed to the desired spray location.

Operation

During Operation

1. After arriving at spray location, open the hydraulic valves on the boom folding cylinders. (If using a hydraulic fold boom).
2. Check for any obstructions, and open the boom to the fully extended position.
3. If your sprayer is equipped with hydraulic boom height adjustment, use the tractor's hydraulic controls to raise or lower the boom to the desired spray height. If your sprayer is equipped with manual boom height adjustment, use the boom winch to adjust the boom height. NOTE: If during operation the boom contacts the ground or any other stationary object potential damage may occur and void the manufacturer's warranty. Be aware of any obstructions that could harm the boom. During spraying a hydraulic boom can be raised and lowered as needed. NOTE: If the hydraulic boom is not operating smoothly, or it is operating too quickly, you may need to adjust your tractor's hydraulic flow.
4. Engage the pump. The tractor should be running at the RPM rate determined when you calibrated your sprayer. While spraying always remember to maintain a constant level of speed and RPM (rates found when calibrated).
5. For electric controls, adjust the pressure using the sprayer's control console. For non-electric controls, adjust the pressure using the pressure regulating valve (see "Control" section for details). Make sure the sprayer's pressure is the same as the pressure determined earlier in the preceding calibration steps, or select the desired application rate on your automatic rate control.
6. Prepare the sprayer for spraying. Open the boom control valves (manual controls), or flip the boom control switches to the "ON" position (electric controls), or operate the spray gun (if applicable). Boom section valves can be operated independently to ensure complete coverage and minimize overlap. NOTE: When you open the boom sections, the pressure may fluctuate. If this happens simply re-adjust the pressure (see "Control" section).
7. At the end of the spray application area, turn off boom sections, using the boom section valves or master valve (manual controls), or the sections switches or master switch (electric controls).

Following Operation

1. Upon completion of spraying, or if the tank is empty, turn off the boom sections and stop the sprayer pump by disengaging the tractor's PTO system, or the hydraulic drive system. IMPORTANT: Operating the pump when the tank is empty or suction valves are closed will void the manufacturer's warranty.
2. Upon completion of spraying, always rinse the sprayer with clean water and spray all rinsate on crops as directed by the chemical manufacturer.
3. Before transporting the sprayer, the boom needs to be completely closed. Close the hydraulic locking valve near the hydraulic folding cylinder (if applicable) to allow for safe transportation of the sprayer.
4. Before storing the sprayer ensure that the sprayer's tank, pump, and boom are completely rinsed out. This can be done by manually rinsing the sprayer's tank and running the clean water through the sprayer's boom until the system is completely rinsed out. All rinsate must be disposed in a manner recommended by the chemical manufacturer.
5. Excess water can be drained by removing the bowl of the in-line filter located below the tank.
6. Before removing hydraulic hoses turn off tractor and cycle hydraulic levers to release any hydraulic pressure. Unhook the sprayer and store the sprayer on a hard level surface in a location away from human and livestock activity.

Instructions for Clearing Blockages and Cleaning

1.) Clearing Blockages

If the sprayer encounters issues with low spray volume, it may be due to a blockage in one or some of the plumbing components. Some common blockage issues that can occur, along with how to resolve the issue, are detailed in the text below. If any fittings, filters, or plumbing parts are damaged, contact your authorized CropCare® dealer for replacement parts.

NOTE:

-The best way to avoid blockages is to make sure proper agitation is occurring while adding chemicals to tank, applying, and thoroughly rinsing all plumbing components after each time spraying.

-ALWAYS follow the chemical manufacturer's disposal instructions when disposing clean out rinsate and chemical build up.

-Wear all necessary PPE recommended by the chemical manufacturer (i.e. chemical resistant gloves, safety goggles, chemical resistant suit) when clearing out blockages and handling chemical build up.

- Sometimes hose fittings and small diameter hoses can accumulate chemical build up if the sprayer is not properly rinsed after spraying. After locating a clogged fitting or hose, remove it and try to dislodge blockage. Once blockage is removed, reinstall the hose or hose fitting.
- This sprayer is outfitted with a Main suction line filter and Nozzle tip filters. These filters can become clogged over time from foreign debris or chemical build up. Remove any affected filter and rinse thoroughly with water until filter is clean and reinstall filter (see "Maintenance Procedures" section).
- Tanks have sumps and low points that over time can accumulate debris and chemical build up. If debris or chemical build up is present, remove and discard debris carefully to minimize chemical exposure.

2.) Cleaning Sprayer

NOTE:

-ALWAYS follow the chemical manufacturer's disposal instructions when cleaning sprayer.

-Wear all necessary PPE recommended by the chemical manufacturer according to chemical manufacturer(i.e. chemical resistant gloves, safety goggles, chemical resistant suit) when cleaning sprayer.

- It is good practice to clean the sprayer, inside and out, after every use. Keeping the sprayer clean helps prolong the life of the sprayer and sprayer components.
- For instructions regarding rinsing the internal components of the sprayer, refer to the "Maintenance Procedures" section.
- Select a soak away area where the cleaning rinsate can be safely be disposed. Most pesticide washings can be washed off on a soak away. A soak away is an area that is currently not being used for crops. That soak away CANNOT directly runoff into wells, springs, streams, water courses, ditches, or sewers.
- A pressure washer can be used to wash down the sprayer. Do not directly spray high pressure water onto electrical components, spray tips, or any other moisture or pressure sensitive components.

Troubleshooting

-Information for fault diagnosis and remedy of problems in operation.

Issue	Probable Cause	Solution
No pressure on start up or Unable to build adequate pressure	Pump is air-locked	Prime the pump as directed in owner's manual.
	Regulating valve set incorrectly (fully opened for bypass, fully closed for throttling)	Use pressure adjustment switch, knob, or handle to increase pressure.
	Flow from tank to pump is inhibited.	Clogged suction hose, fitting, or filter screen, or incorrect valve position (see operation instructions in owner's manual for correct valve position).
	Flow from pump to controls inhibited.	Incorrect valve position (see operation instructions in owner's manual for correct valve position).
	Air leak on suction side of sprayer plumbing	Locate the leak and fix it.
	a. Defective O-ring or gasket in suction filter.	Replace the O-ring or gasket.
	b. Hole or crack in suction hose	Replace hose.
	c. Cracked or broken plastic fitting	Replace fitting.
	Defective gauge or gauge isolator	Confirm that isolator is filled with oil and that gauge operates correctly.
	Low fluid level in tank	Add material and fluid as necessary to complete application.
	Defective pump seal (evidenced by fluid leak from weep hole)	Replace seal. (See pump owner's manual for details.)
Defective pump	Repair or replace pump.	
Pressure loss during operation	Missing or damaged nozzle body or nozzle	Replace nozzle or nozzle body.
	Clogged suction filter screen	Remove filter screen from filter bowl and clean or replace.
	Low fluid level in tank	Add material and fluid as necessary to complete application.
	Clogged or restricted pump impeller, hose, or fitting	Remove pump, hose, or fitting and unclog or replace as needed.
	Leak on suction side of sprayer plumbing	Locate the leak and fix it.
	a. Defective O-ring or gasket in suction filter.	Replace the O-ring or gasket.
	b. Hole or crack in suction hose	Replace hose.
	c. Cracked or broken plastic fitting	Replace fitting.
	Agitation nozzle orifice missing	Reduce agitation flow using the agitation control valve. When tank is empty and clean, replace orifice.
	Defective gauge or gauge isolator	Confirm that isolator is filled with oil and that gauge operates correctly.
Defective pump seal (evidenced by fluid leak from weep hole)	Replace seal. (See pump owner's manual for details.)	
Pressure increasing during operation	Agitation nozzle orifice clogging	Adjust pressure to continue spraying then clear or replace orifice when sprayer is empty and clean.
	In-line section filters, nozzle, or nozzle screens clogged	Remove filter screen from filter bowl and clean or replace. Remove and clean or replace nozzle or nozzle screen.
Unable to adjust pressure up or down	Bypass line tank valve closed, or obstruction in bypass line (bypass plumbing system only).	Open bypass line tank valve (if equipped), or remove obstruction in bypass line.
	Pressure regulating valve not operating	Check wiring and wiring connections (electric valve), or repair or replace regulating valve

Troubleshooting

Issue	Probable Cause	Solution
Unable to completely reduce pressure with the regulating valve	Excessive pump flow	Reduce engine speed and/or increase agitation flow.
Pressure on rate control console (if equipped) does not match gauge pressure	In-line section filters, nozzle, or nozzle screens clogged	Remove filter screen from filter bowl and clean or replace. Remove and clean or replace nozzle or nozzle screen.
	Missing or damaged nozzle body or nozzle	Replace nozzle or nozzle body.
	Incorrect calibration value or console setting	Verify control console settings.
Pump slow to prime or will not prime	Leak on suction side of sprayer plumbing	Prime the pump as directed in owner's manual.
	Flow from tank to pump is inhibited/restricted	Ensure that valves are in correct position.
	Clogged suction filter screen	Remove filter screen from filter bowl and clean or replace.
	Clogged or restricted pump impeller, hose, or fitting	Remove pump, hose, or fitting and unclog or replace as needed.
	Leak on suction side of sprayer plumbing	Locate the leak and fix it.
	a. Defective O-ring or gasket in suction filter.	Replace the O-ring or gasket.
	b. Hole or crack in suction hose	Replace hose.
c. Cracked or broken plastic fitting	Replace fitting.	
Pump leaking fluid	Defective pump seal, gasket, or O-ring	Replace seal, gasket, or O-ring. (See pump owner's manual for details.)
	Pump housing damaged	Replace component or pump. (See pump owner's manual for details.)
Pump noisy/pulsating (Diaphragm pump only)	Flow from tank to pump is inhibited/restricted	Ensure that valves are in correct position.
	Clogged suction filter screen	Remove filter screen from filter bowl and clean or replace.
	Insufficient pressure in pulsation dampener	Charge dampener with air as specified in pump owner's manual
The Pump oil level low, overflowing, or changing color (Diaphragm pump only)	Pump diaphragms damaged	Replace diaphragms. (See pump owner's manual for details.)
Poor tank agitation	Incorrect agitation valve setting	Open agitation control valve to allow more flow to agitator jet(s).
	Clogged or missing agitator orifice	Clear or replace agitator orifice when sprayer is empty and clean.
	Engine speed is too low	Ensure that tractor PTO is operating at 540 RPM.
	Clogged or restricted pump impeller, hose, or fitting	Remove pump, hose, or fitting and unclog or replace as needed.
	Clogged suction filter screen	Remove filter screen from filter bowl and clean or replace.
	Pump not functioning correctly	Repair or replace pump.
Unable to completely empty spray tank	Too much return flow to tank	Close agitation valve temporarily to empty tank.
	Sprayer tank is not level	Move sprayer to level area, and raise or lower hitch clevis (trailer sprayer) or adjust top link (three-point hitch sprayers) if necessary.
Boom section(s) are not shutting off	Section valve not operating or leaking internally	Check wiring and wiring connections (electric valves), or repair or replace section valve seals/seats (electric or manual valves).
Boom section(s) are not turning on	Section valve not operating	Verify that power is being supplied to valve (electric valves only).
	System pressure too low	Ensure that operating pressure is at least 15 psi.
Nozzle(s) not shutting off	Bad nozzle body diaphragm or no-drip check valve	Repair or replace nozzle body.
Nozzle(s) not turning on	Pressure too low	Ensure that operating pressure is at least 15 psi.

Operation

Plumbing Diagrams

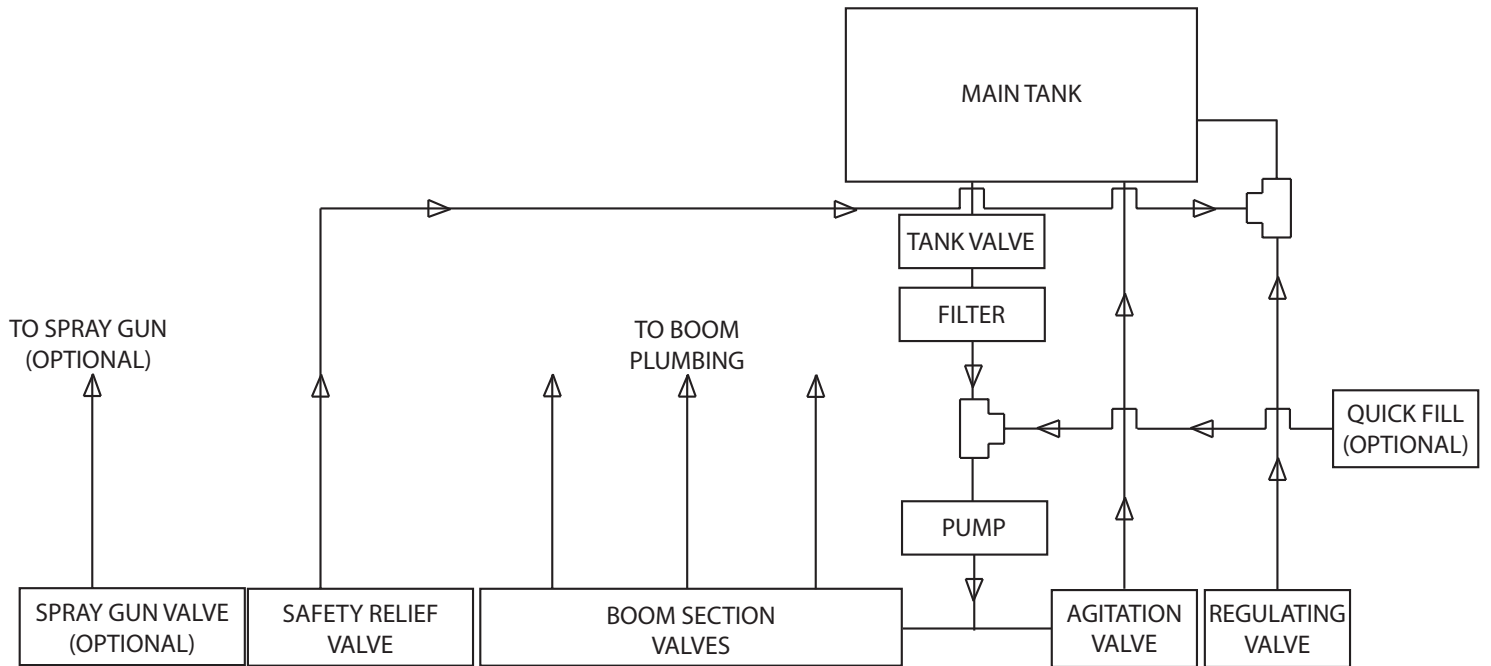

Figure 1: Electric Controls with Safety Relief Valve (Used with Roller Pumps)

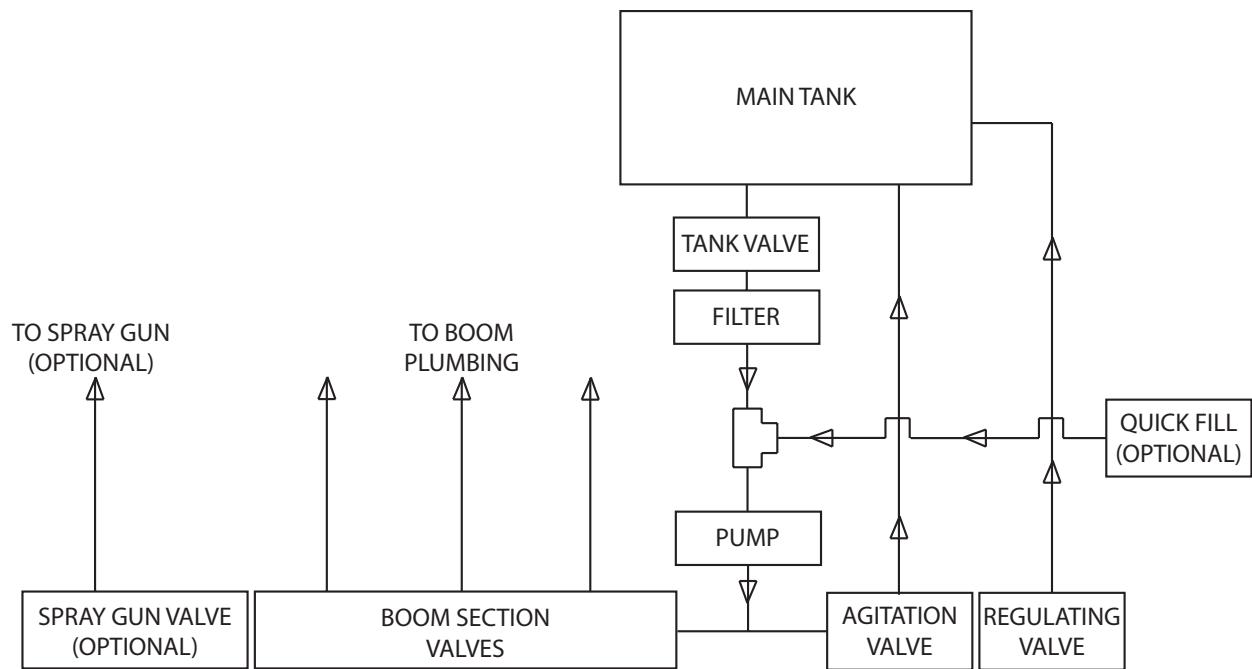

Figure 2: Electric Controls (Used with Centrifugal Pumps)

Operation

Plumbing Diagrams

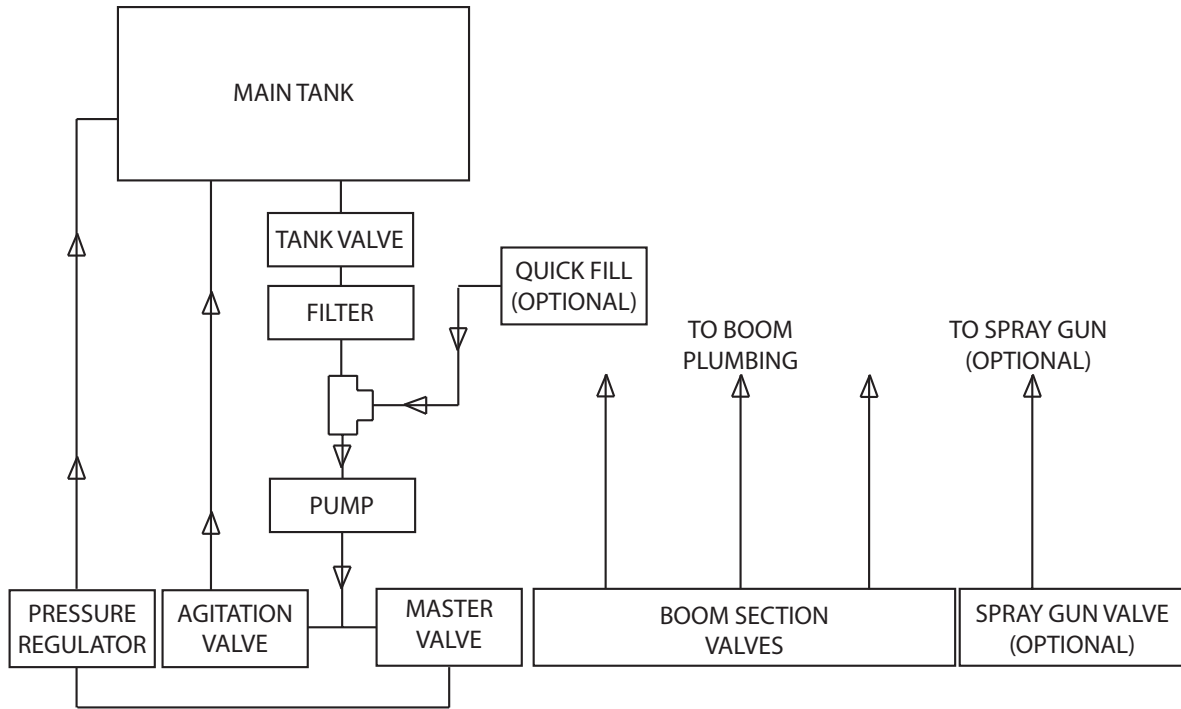

Figure 3: Manual Controls (Used with Centrifugal or Roller Pumps)

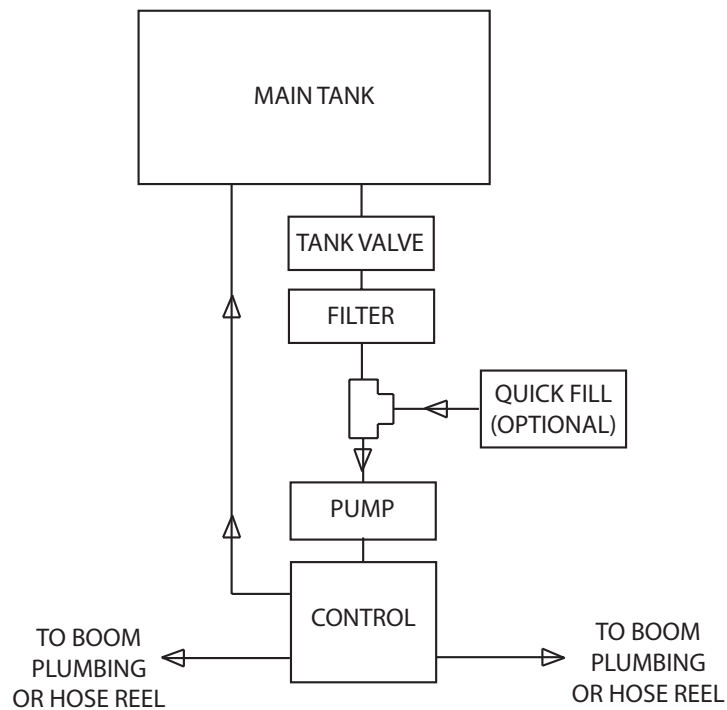

Figure 4: Manual Controls (Used with Diaphragm Pumps)

Maintenance and Adjustments

Maintenance Schedules

-Information concerning periodic maintenance tasks and the recommended frequency.

Frequency	Maintenance Tasks
Every Use	Check for broken or stressed parts
	Check for leaks (Tighten hose clamps and replace hoses as necessary)
	Check for loose connections (hardware)
	Flush sprayer fluid system with fresh water
	Tip strainers: should be taken out and rinsed.
	Suction Line and Boom in-line strainers: should be taken out and rinsed.
Every Season	Wash the exterior of the sprayer with mild detergent.
	Spray Nozzles: Check spray pattern imperfections due to wear, replace tips as necessary
Refer to Owner's Manuals	Winterize the sprayer before the temperature falls below 30 degrees F
	Pumps: Refer to your Pump's Owner's Manual for service intervals and details
	Booms: Refer to your Boom's Owner's Manual for service intervals and details

Maintenance Procedures

-Instructions for each task, including identification of any tools, test equipment, replacement parts or other service required.

Every Use

- Perform a visual and physical inspection for any worn parts, loose bolts, damaged hoses, or other visible problems. Make all necessary repairs before spraying. To order parts or receive technical help, please contact your local CropCare® dealer.
- After each use, ensure that the sprayer's tank, pump, and boom are completely rinsed out. This can be done by rinsing the sprayer's tank and running the clean water through the sprayer's boom until the system is completely rinsed out. All rinseate must be sprayed on the field as recommended by the chemical manufacturer. Excess water can be drained by removing the bowl of the in-line filter located below the tank.
- Any cast-iron roller pumps must be removed and flushed with oil.
- Tip strainers should also be taken out and rinsed on a regular basis. Tip strainers are the small screens located behind each spray nozzle on the boom (Figure 2).

Every Season

- At the beginning of the season, using water, check spray patterns on the nozzles. If any spray nozzles appear to be worn, replace as needed.
- The suction line filter, located below the tank, and the boom line filters, located on the center section of the boom, should have the screens taken out and rinsed.
- NOTE: Follow chemical manufacturers guidelines for proper cleaning of the strainers.
- NOTE: Be careful not to lose the gasket in the filter bowl. A missing gasket will cause the strainer to leak.

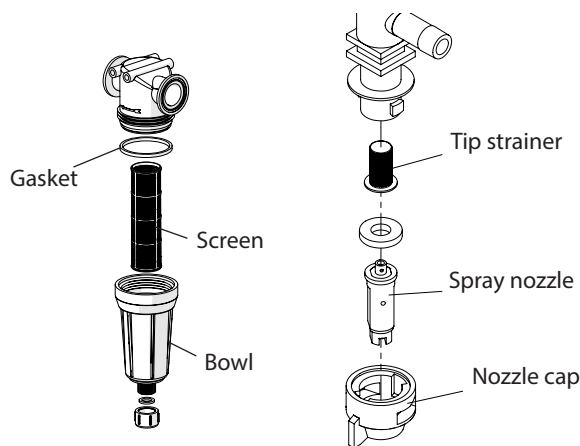

Figure 1: In-line filter

Figure 2: Nozzle breakdown

Maintenance and Adjustments

Every Season Continued...

- Tip strainers should also be taken out and rinsed on a regular basis. Tip strainers are the small screens located behind each spray nozzle on the boom.
- The winterization process should be undertaken before freezing conditions and/or after each season of use. See “Winterizing The Sprayer” section for details.
- Wheel bearings must be greased and the bearing pre-load must be properly set before use every season to avoid wheel bearing failure.
- Park the sprayer on a solid, level surface, and secure the sprayer with wheel chocks. Use a hydraulic jack to lift one wheel at a time, and support the axle with a jack stand. **WARNING:** Do not at any time crawl under the sprayer while it is being supported by the hydraulic jack.

Preparing the Sprayer for Winterizing

-It is essential that you winterize your sprayer to avoid damage and to allow for optimal performance. The winterization process should be undertaken before freezing conditions and/or after each season of use. Failure to winterize your sprayer will void the manufacturer's warranty.

1. Verify that the sprayer's plumbing system has been rinsed thoroughly and rinse water has been disposed of according to the chemical manufacturer's recommendations.
2. Drain any remaining water from the sprayer's plumbing system by opening the suction and tank valves. Then remove the drain cap from the suction filter and capture all fluid in a container. When system is drained, ensure that the rubber gasket is in place and replace drain cap onto suction filter. Dispose of liquid according to the chemical manufacturer's recommendations.

Winterizing the Sprayer

1. Pour 12 gallons of nontoxic RV antifreeze (propylene glycol) into the sprayer tank.
2. **NOTE:** Do not use standard automotive antifreeze (ethylene glycol). It is toxic to humans and animals and causes a disposal hazard.
3. Fully open the agitation control / bypass valve (see “Controls” section for details).
4. Engage the sprayer pump and operate tractor at moderate engine speed. If pump does not prime, bleed air from the system using the bleeder valve on the pump (see “Priming the Pump” section).
5. Open all boom section control valves until RV antifreeze is observed spraying from all nozzle bodies or until tank is empty, then disengage pump.
6. Store the sprayer in a dry location, out of the elements and away from human or animal activity.
7. When operating the sprayer for the first time following winterization, flush the sprayer with fresh water to remove the RV antifreeze from the system and thoroughly inspect the sprayer for leaks or any signs of damage as a result of freezing.

IMPORTANT: Do not, under any circumstances, run any petroleum based substance (such as diesel fuel) through the sprayer. This will cause damage to sprayer components and will void the manufacturer's warranty.

Maintenance and Adjustments

Maintenance Materials

Specifications, including quantities / capabilities for normal maintenance materials, such as:

1. RV nontoxic antifreeze (See “Winterizing The Sprayer” section)
 2. General-purpose lithium grease (See “Maintenance Procedures” section)
 3. High temperature lithium complex grease i.e. Castrol Pyroplex Red (For greasing spindle bearings).
 4. Oil for Pump as specified by pump manufacturer (see pump owner’s manual).
 5. Oil for Engine as specified by engine manufacturer (see engine owner’s manual).
-

Adjustments

The sprayer has the following adjustments:

- The hitch can be adjusted up or down to accommodate varying tow vehicle hitch heights while keeping the sprayer level. (IMPORTANT: The hitch must be secured to the frame using all of the fastening bolts. Failure to do so will void the manufacturer’s warranty.)
 - The sprayer’s axles are able to be adjusted out in 6” increments for different row spacings. (IMPORTANT: After making any adjustments the axles must be secured to the frame using all of the fastening bolts. Failure to do so will void the manufacturer’s warranty.)
 - Refer to the boom’s owners manual for boom adjustment instructions.
-

Storage

The following procedures are to be taken to prepare the sprayer for storage.

- Before storage, ensure that the sprayer’s tank, pump, and boom are completely rinsed out. This can be done by rinsing the sprayer’s tank and running the clean water through the sprayer’s boom until the system is completely rinsed out. All rinsate must be sprayed on the field as recommended by the chemical manufacturer. Excess water can be drained by removing the bowl of the in-line filter located below the tank.
- Store the sprayer in a safe, dry location away from the elements and human and animal activity.
- See engine owner’s manual for storage information.

IMPORTANT: If there will be freezing conditions during storage the sprayer needs to be winterized. (See “Winterizing The Sprayer” for details). Failure to do so will void the manufacturer’s warranty.

Transportation

Transportation



Transporting the Sprayer



- When transporting the sprayer on public roads, always follow state and local regulations regarding safety and transportation requirements. Use the necessary lights and slow moving vehicle (SMV) emblems.
- Never exceed the tractor, or alternative vehicle's load and/or tow ratings.
- When transporting the sprayer, the sprayer's boom must be in the fully closed position and secured. If the sprayer is equipped with a hydraulic boom, the boom is secured by closing the ball valve located on the hydraulic folding cylinder (Figure 1).
- Check lighting before traveling.
- Make sure SMV sign (Figure 2) is not blocked or bent.



Figure 1: Hydraulic valve warning decal (DE25)

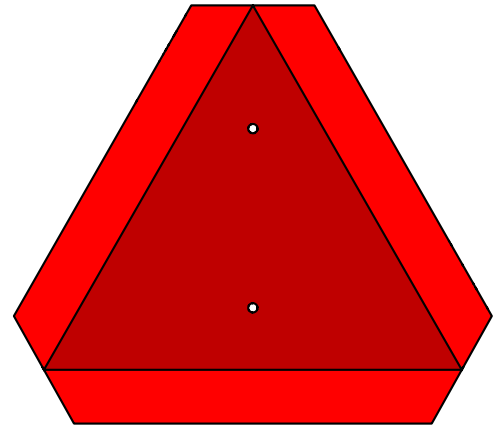

Figure 2: Slow Moving Vehicle Sign (SMV)

Accessories and Attachments

Gas Engine Electric Start Option

Connecting to Battery:

- NOTE: Battery must be a 12-volt battery with an ampere hour rating of at least 18 Ah.
- NOTE: Be careful not to connect the battery in reverse polarity, as this will short circuit the battery.
- NOTE: The engine is not equipped with an alternator to charge the external battery. The external battery will need to be recharged periodically.

WARNING: Batteries are hazardous because they contain caustic acid, can emit explosive gases, and can cause electric shock.

WARNING: Caution must be exercised when making connections to a battery to avoid shock and contact with the acid, and to prevent any sparking that could lead to an explosion.

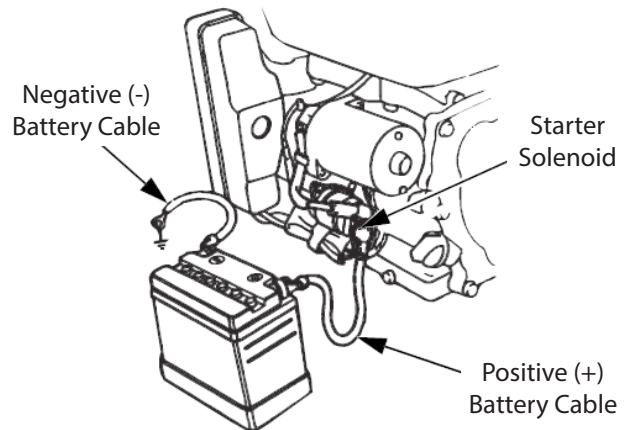

1. Connect the battery positive cable to the starter solenoid terminal as shown.
2. Connect the battery negative cable to an engine mounting bolt, or other good engine ground position.
3. Connect the battery positive cable to the battery positive terminal.
4. Connect the battery negative cable to the battery negative terminal.

Accessories and Attachments

Electric Hose Reel Option

Connecting to Battery:

- NOTE: Be careful not to connect the battery in reverse polarity, as this will short circuit the battery.
 - NOTE: Use a 30 amp fuse in the positive (+) line from the battery to the terminal for inside the junction box.
 - NOTE: Use 10 ga AWC wire for leads from battery.
1. Loosen the four screws to remove the cover from the junction box.
 2. Loosen the strain relief (a) and route wires up through the fitting into the box.
 3. Crimp ring terminals onto the ends of the wires. Attach the positive (+) wire to the terminal (b), and the negative (-) to the terminal (c).
 4. Secure wires in place by re-tightening the strain relief.
 5. Route wires to battery and secure on battery terminals.

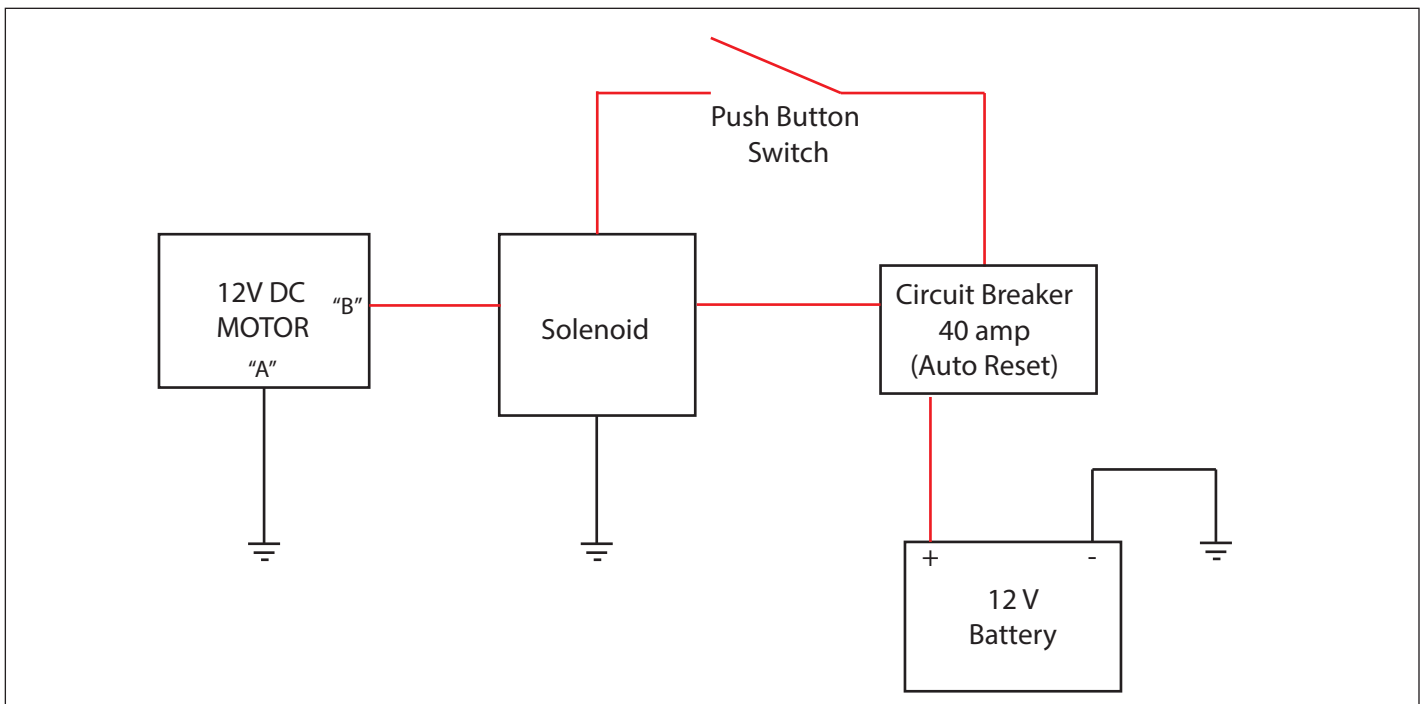
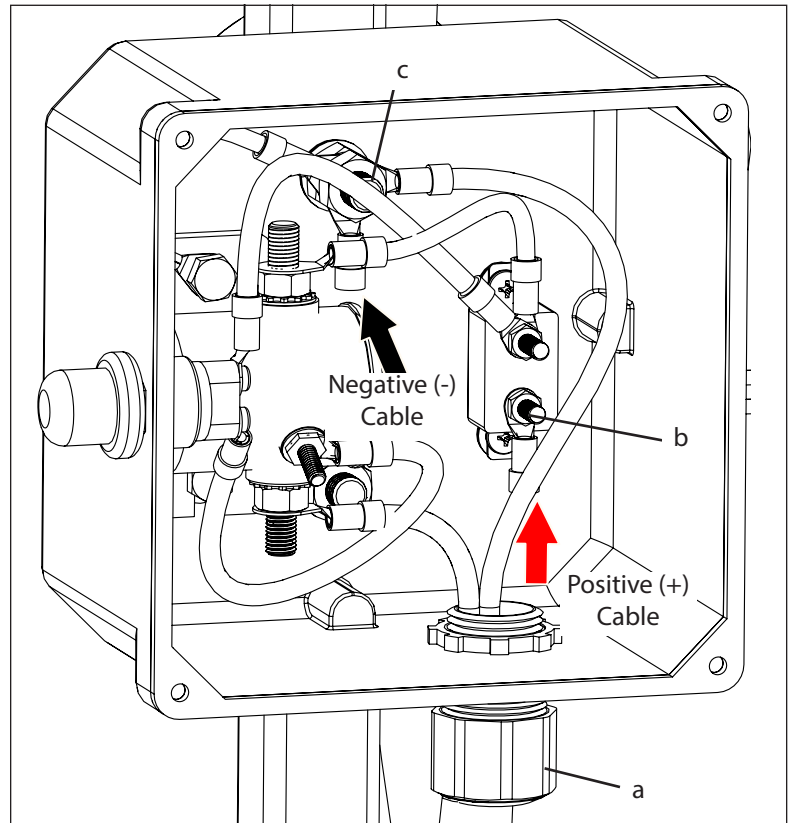

CropCare® Limited Warranty

Warranty Coverage

CropCare® hereby provides a Limited Two (2) Year Warranty on the Products manufactured by CropCare® that such Products shall be free from manufacturer's defects in any of the Product's components in the 24 month period following the original date of purchase from the authorized dealer (the "Warranty Period"). CROPCARE® HEREBY EXCLUDES AND DISCLAIMS ANY AND ALL OTHER WARRANTIES, STATUTORY, EXPRESS OR IMPLIED, INCLUDING WITHOUT LIMITATION ANY IMPLIED WARRANTY OF MERCHANTABILITY OR FITNESS FOR ANY PARTICULAR PURPOSE AND ANY WARRANTY ARISING FROM USAGE OF TRADE OR COURSE OF DEALING. Defective components will be repaired or replaced at the discretion of the manufacturer. It is the responsibility of the purchaser to return warranted components to the manufacturer. This Product Warranty is limited to the repair or replacement of Product components only. CROPCARE® IS NOT TO BE HELD LIABLE FOR INCIDENTAL OR CONSEQUENTIAL DAMAGES OF ANY KIND. This Product Warranty covers the purchaser of this Product and any other owners who own it during Warranty Period.

To retain the Product Warranty, the Product must be operated and maintained as set forth by its owner's manual. For warranty service, please have a copy of the purchase invoice available.

Warranty is Void if:

1. The Product has been subjected to, in the opinion of CropCare®, negligent handling, misuse, an accident or if the instructions in the owner's manual were not completely followed.
2. The Product's components have been altered in any manner or repairs have taken place with unapproved parts.
3. The Product and its components were subject to freezing or freezing conditions. The Product must have been winterized as per the maintenance instructions to retain the Product Warranty.
4. A non-compatible chemical was used and/or if the Product operator failed to rinse all chemical residue out of the Product's components after use.
5. A petroleum-based, oil-based, or flammable product was used and caused damage to the pump, tank, hoses, or any other component.

Getting Warranty Service

All Product Warranty claims must be made through an authorized CropCare® dealer. All warranty claims must be submitted with an invoice or a proof of purchase that denotes the purchase date and place of purchase. If you have any questions or comments concerning this warranty, please contact an authorized CropCare® dealer.

Ordering Parts

Please contact your authorized CropCare® dealer to order replacement parts for your product.

Parts List & Breakdowns

-Parts lists are available on www.CropCareEquipment.com/equipment-build-lists.php. Breakdowns can be acquired through your authorized CropCare® dealer.

CROPCARE

by PBZ[®]

Manufactured by PBZ LLC
A Paul B Zimmerman Inc. Company
www.CropCareEquipment.com